

OD01



- Small Package
- Good stability oven controlled crystal oscillator

Table 1 Specifications

Parameter	OD01
Frequency Range	5~40MHz
Standard Frequency	5, 10, 8.192, 12, 13, 16.384, 20, 26, 38.88MHz
Frequency	vs Operation Temp.Range $\pm 1 \times 10^{-7} \sim \pm 5 \times 10^{-7}$, Options See Table2
Stability	vs Vcc Change $\pm 5\%$ $\pm 5 \times 10^{-9}$
	vs Load Change $\pm 10\%$ $\pm 5 \times 10^{-9}$
	vs Aging $\pm 5 \times 10^{-7}$ /year @25°C after 30 days operation
Operation Temperature Range	Options See Table 2
Supply Voltage	5V, 9V, 12V (option code 5, 9, 12)
Current Consumption (@12Vcc)	500mA max at Turn-on, 200mA max after warm up at 25°C
Output	TTL/CMOS, Code is "T"
SSB Phase Noise (10MHz, typical)	-115dBc/Hz@10Hz
	-130dBc/Hz@100Hz
	-135dBc/Hz@1KHz
	-135dBc/Hz@10KHz
Warm-up Time@25°C Typical	$\pm 1 \times 10^{-7}$ after 10 minutes
Frequency Adjustment (from OV to Vref.)	$\pm 3 \times 10^{-6}$
Package	25A
Storage Temperature Range	-40~+85°C

Table 2 Frequency Stability vs Operation Temperature Range(Ref to 25°C) and Option Code

	$\pm 1 \times 10^{-7}$	$\pm 2 \times 10^{-7}$	$\pm 5 \times 10^{-7}$
0~50°C	A1.7	A2.7	A5.7
-10~55°C	L1.7	L2.7	
-20~60°C		N2.7	N5.7

OCXOs

Part Numbering Key

Sample Part Numbers	SERIES	SUPPLY VOLTAGE	OUTPUT FORM	FREQ.STABILITY vs. TEMP	PACKAGE CODE	FREQUENCY
	OD01-5T-N2.7-25A @20.000MHz	OD01	5=5V	T=TTL/CMOS	See Table2	25A
	OD02	9=9V				
		12=12V				
	OD01	5	T	N2.7	25A	20.000MHz

About OCXO

Package 50A Unit:mm

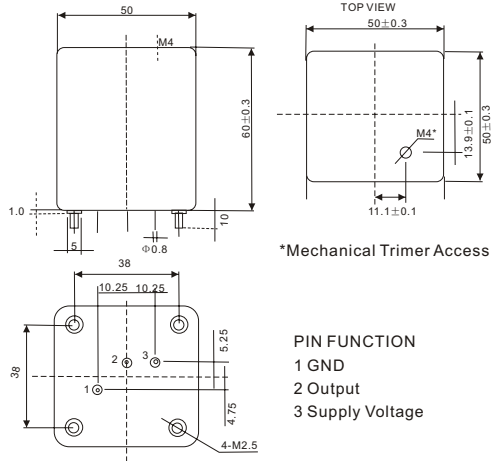

Package 50E Unit:mm

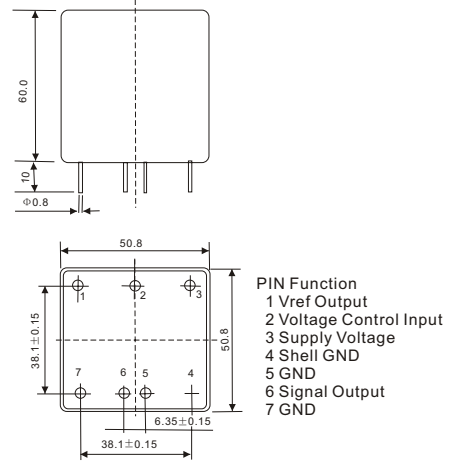

Package 50A1 Unit:mm

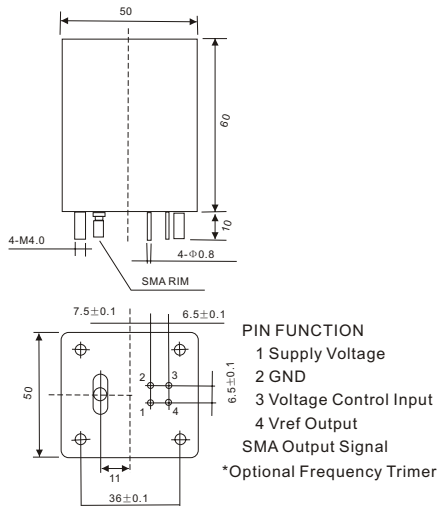

Package 50B,50C,50D Unit:mm

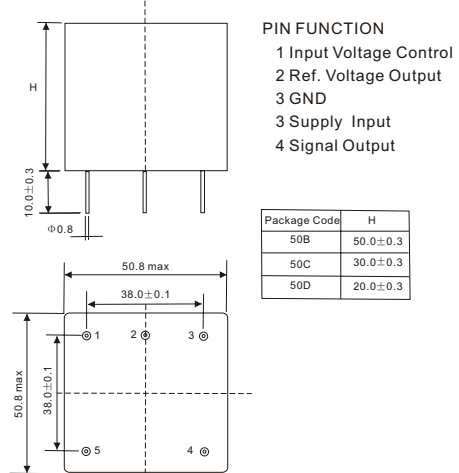

Package 38A Unit:mm

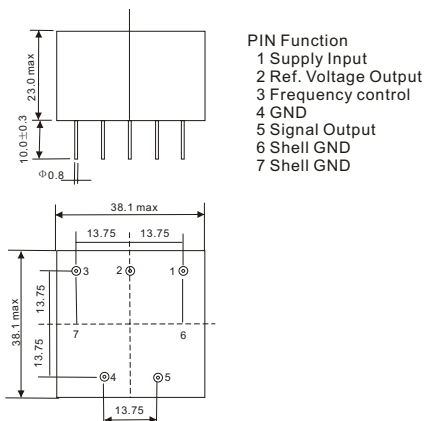

Package 36A Unit:mm

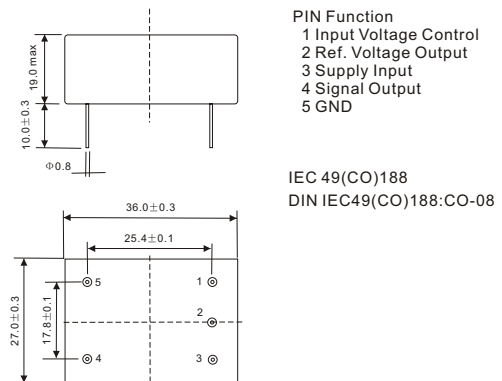

About OCXO

Package 25A

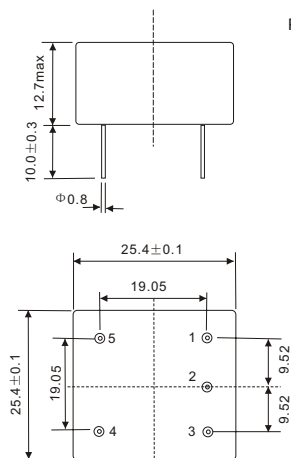

- PIN Function
- 1 Input Voltage Control
 - 2 Ref. Voltage Output
 - 3 Supply Input
 - 4 Signal Output
 - 5 GND

Marking

- 1. Logo;
- 2. Frequency;
- 3. Part Number;
- 4. Product ID;
- 5. Year + Month;
- 6. Company Name;

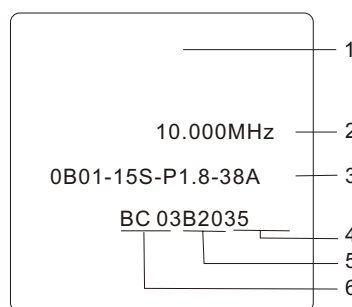

1.Environmental Specification.

- Shock: 50g for 11ms, 3 shocks in each direction of main axis.
- Vibration: 10 to 500Hz, 10g

2.About Frequency Adjustment.

Manual Freq. Adjust Connection

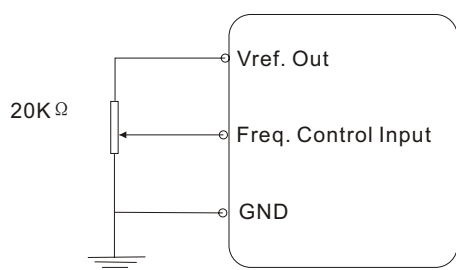

Fine Manual Freq. Adjust Connection

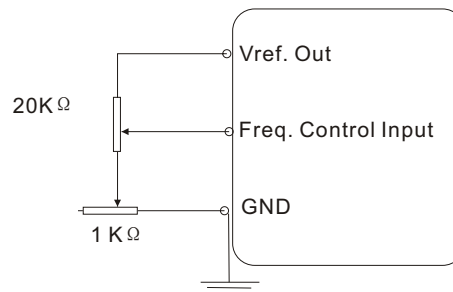

External Freq. Control Voltage Connection

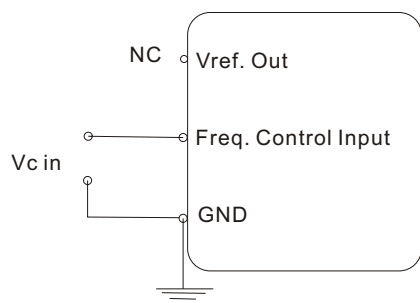

Freq. Control Voltage and Manual Adjust

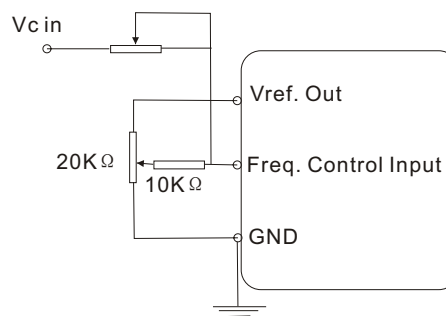

ORDER SHEET



Customer OCXO Requirements Form
用户定制产品要求表

*Please check Part Number first and standard product ◆Minimum specification information required for pricing
* 请先查看“产品编号”并尽量选用标准产品 ◆必须填写的指标要求，否则无法报价

Frequency 工作频率	◆		MHz
Output Waveform 输出波形	◆		
Output Level/Load 输出电平/负载	◆		
Harmonics/Non-Harmonics 谐波/非谐波抑制			
Tr/Ts 上升/下降时间(Square Wave, 方波)			nS
Duty Cycle 占空比(Square Wave, 方波)			%
Supply Voltage 电源电压	◆		Vdc
Power		Warm-up 预热时	mA or Watts
Consumption 电流消耗		Stabilized@25℃ 稳定时	mA or Watts
Warm up Time 预热时间			Minutes
Operation Temperature Range 工作温度范围	◆		℃
Phase Noise 相位噪声		10Hz	dBc/Hz
		100Hz	dBc/Hz
		1KHz	dBc/Hz
		10KHz	dBc/Hz
Short Time Stability 短稳			
Frequency Stability 频率稳定度		vs Suooly Voltage Change	
		vs Load Change	
Aging 老化率		vs Operation Temperature	◆
		After 7 days on power	/Day
		After 30 days on power	◆ /Year
Frequency Adjust 频率微调 (选择1种)	Electrical <input type="checkbox"/> 电调 Trimmer <input type="checkbox"/> 内部机械	Range 范围	◆ ± ppm
		Linearity 线性度	%
		Slope 极性	Positive/negative
		Control Voltage	Vdc
Package Size 外形尺寸与引线定义 (如果是非标准尺寸, 请附图纸)	◆		
Marking 产品印字			

Additional Notes 其他说明 (如果是标准产品, 请在此填写产品编号)

Name 姓名		Job Title 职务	
Company Name 公司			
Adress 地址			Postcode 邮编
Telephone 电话		Fax 传真	
E-Mail		HTTP://	